



# RISMAQ

## RPD-3500

---

### Drilling & Cutting Center for Alu. Guide Channels

It is designed to drill and cut for roller shutter aluminum guide channel profiles.

[www.rismaq.com](http://www.rismaq.com)

Technical Drawing

**Drilling & Cutting Center for Alu. Guide Channels**

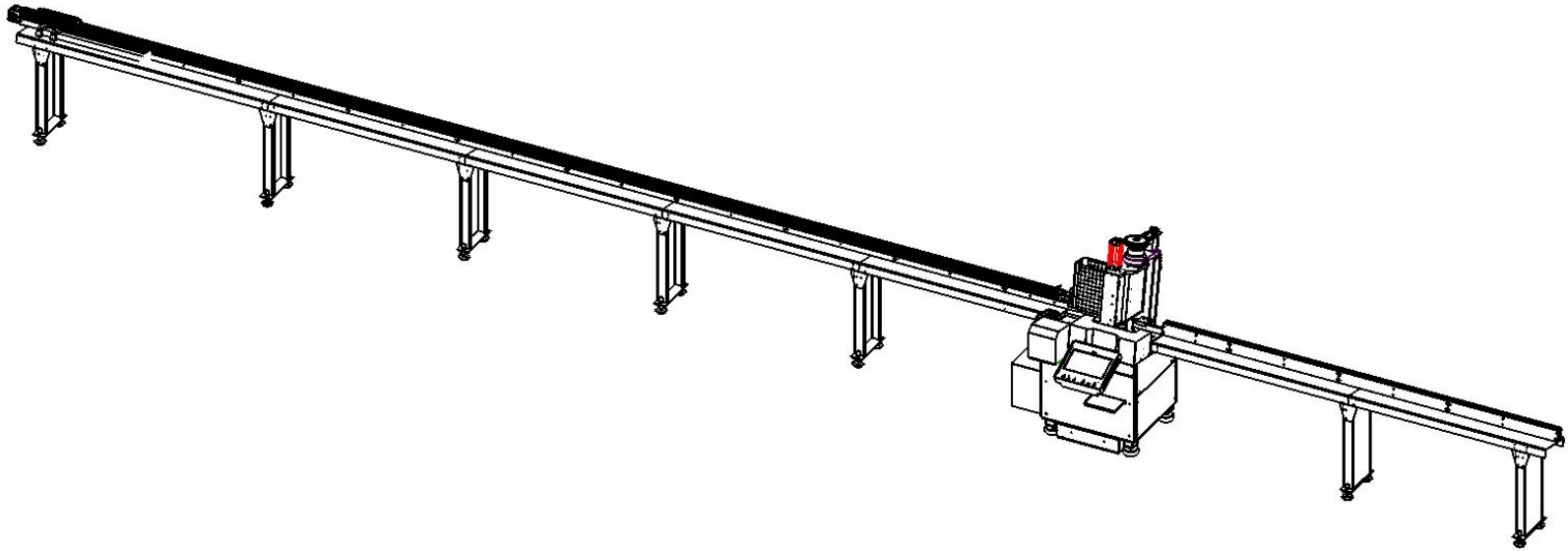

**Industrial** revolution.



English

## Drilling & Cutting Center for Alu. Guide Channels

- ✓ It is designed to drill and cut roller shutter aluminum guide channel profiles.
- ✓ 3 axes servo-motor control technology.
- ✓ Pc controlled with Windows operating system.
- ✓ Easy and fast data transfer because of Pc (by usb memory, cable, cd, wireless, Ethernet, mail etc.)
- ✓ It drills 2 different hole diameter
- ✓ Adjustable hole drilling position for every kind of guide channels.
- ✓ Unlimited drilling and cutting data memory.
- ✓ Thanks to 15.6" lcd control screen for being user-friendly.
- ✓ Automatic push type digital measuring system with servo motor technology.
- ✓ Drilling speed of profile can be adjusted.
- ✓ Cutting speed of profile can be adjusted.
- ✓ Clean surface cutting because of high saw rotation.
- ✓ Saw disc is 400 mm.
- ✓ Remote control service technology.

### OPTIONAL:

- ✓ Barcode system
- ✓ Saw dust collector

**Industrial** revolution.



RISMAQ

[www.rismaq.com](http://www.rismaq.com)